

# SYNTHETIC TURF SYSTEMS

Best-in-Class Solutions for Synthetic Turf Irrigation

**Hunter®**



*Attain new levels of playability with*  
**HUNTER ST SYSTEMS**





## ST-1600 Rotor and Vault System

### *A Complete Solution for Synthetic Turf Irrigation*

The ST-1600 Rotor and Vault System from Hunter Industries is the superior solution for all your synthetic turf irrigation needs. The system brings ST irrigation components together inside one strong enclosure that offers simple access from the top for quick servicing and maintenance. The vault houses a slow-opening, low-pressure-loss control valve, isolation valve, drain valve, quick coupler valve, and a powerful ST-1600 long-range, gear-driven rotor. For large fields, the ST-1600 Rotor can reach a radius range up to 165'. The robust and reliable manifold features premium 3" galvanized ductile iron components with heavy-duty, grooved Victaulic™ fittings. ST Systems allow easy access to all components for better serviceability while seamlessly integrating with a variety of surfaces to keep fields intact, playable, and safe.

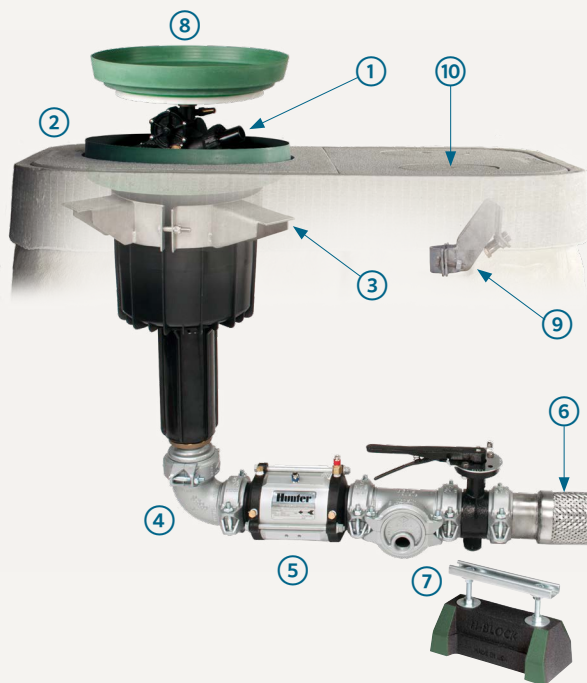

#### ST-1600-KIT SYSTEM COMPONENTS

1	ST-1600-HSB	Synthetic turf rotor
2	ST-243636-B	Vault
3	ST-BKT-1600	Bracket for rotor
4	ST-BVF30-K	Manifold, including 3" fittings, isolation valve, and drain valve
5	ST-V30-KV	3" low-pressure-loss metal valve, including on-off-auto selector and solenoid
6	ST-H30-K	Adjustable stainless steel alignment hose
7	ST-SPT-K*	Adjustable manifold support
8	ST-IBS-1600	Rubber Cover Kit with ST Infill Barrier System
9	ST-BKT-QCV	Hanger bracket for HQ-5-RC Quick Coupler
10	HQ-5-RC	Quick Coupler 1" inlet with 1/4" outlet for key

\* Two required for installation

Victaulic is a trademark of Victaulic Company.

# ST-1600 Rotor



## Total accessibility with maximum throw and power to spare

The ST-1600 Rotor includes a spacious vault system that makes it the premium solution for synthetic turf irrigation. With a powerful throw radius up to 165', the ST-1600 is field-tested and time-proven to be the most reliable gear-driven synthetic turf rotor on the market. It's designed for seamless installation and includes a construction-grade fiberglass shell for easy servicing of all components.

**The riser-mounted ST-1600-HS-BR Rotor is perfect for retrofitting synthetic fields. It's also an ideal dust-control solution for horse arenas, corrals, and pastures.**



ST-1600-HS-B ROTOR

**The exclusive ST Infill Barrier System accommodates every field surface configuration, including infill turf, short non-infill turf, synthetic running track, and in-concrete installations.**



### KEY BENEFITS

- Proven isolated, grease-lubricated gear drive for consistent top performance
- Flexible arc adjustment from 40° to 360° with left and right movable stops
- Ratcheting nozzle turret for simple setup
- Corrosion- and impact-resistant body for ultimate durability
- Stainless steel and brass internal construction for long-term reliability



### ST-1600 SHORT RADIUS NOZZLE KIT P/N 959900

#### OPERATING SPECIFICATIONS

- Radius: 70' to 165'
- Flow: 23.3 to 326.8 GPM
- Operating pressure range: 60 to 120 PSI
- Rotation speed adjustable from: 0 to 65 seconds at 180° sweep at 120 PSI
- 2" BSP inlet
- Nozzle trajectory: 25°
- Nozzles 16 through 26 included
- Warranty: 5-year component part warranty

#### ST-1600 SHORT-RADIUS NOZZLE KIT PERFORMANCE CHART - P/N 959900

Nozzle	Pressure	Radius ft	Flow GPM	Precipitation in/hr	
	PSI			■	▲
8	60	70	23.3	0.92	1.06
	70	72	25.5	0.95	1.09
	90	74	27.3	0.96	1.11
	100	76	29.2	0.97	1.12
10	60	81	37.8	1.11	1.28
	70	84	42.5	1.16	1.34
	90	86	47.1	1.23	1.42
	100	88	51.0	1.27	1.46
12	60	92	53.9	1.23	1.42
	70	94	60.5	1.32	1.52
	90	96	65.7	1.37	1.58
	100	98	71.8	1.44	1.66
14	60	103	69.3	1.26	1.45
	70	105	78.2	1.37	1.58
	90	108	85.5	1.41	1.63
	100	110	92.5	1.47	1.70

#### ST-1600-KIT VAULT SYSTEM

##### 1 Vault

4-piece, thick polymer-concrete vault designed for clean installation and simple servicing

##### 2 Quick Coupler

Quick Coupler Valve provides a convenient water source for washing down the field

##### 3 On-off-auto selector

Valve control functions and solenoid connections are close to the surface for easy access

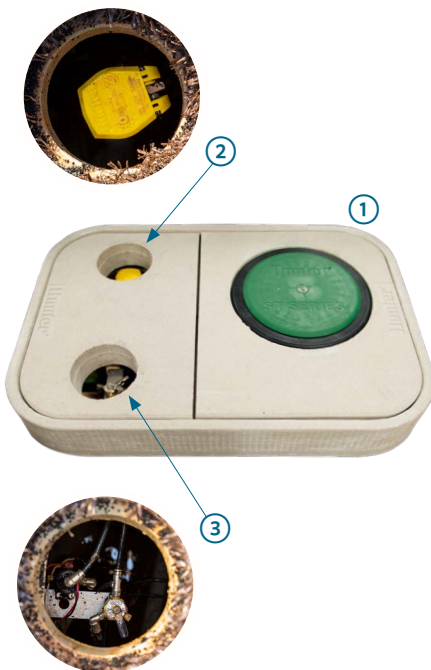

#### ST-1600 NOZZLE PERFORMANCE CHART

Nozzle	Pressure	Radius ft	Flow GPM	Precipitation in/hr	
	PSI			■	▲
16	60	107	96.2	1.63	1.88
	70	115	107.3	1.57	1.81
	90	121	117.8	1.54	1.78
	100	128	127.3	1.50	1.73
	115	135	137.4	1.46	1.69
18	60	112	107.0	1.66	1.91
	70	121	119.4	1.56	1.80
	90	128	131.0	1.54	1.78
	100	133	141.3	1.54	1.78
	115	141	153.2	1.48	1.71
20 Factory-installed nozzle	60	115	144.0	2.10	2.43
	70	128	160.9	1.89	2.18
	90	141	176.5	1.71	1.97
	100	144	190.5	1.76	2.03
	115	148	204.2	1.80	2.08
22	60	118	171.5	2.37	2.73
	70	130	191.8	2.20	2.54
	90	144	210.0	1.94	2.24
	100	151	226.9	1.84	2.12
	115	157	243.1	1.89	2.18
24	60	121	202.1	2.64	3.05
	70	133	225.9	2.46	2.84
	90	148	247.6	2.19	2.52
	100	156	267.4	2.12	2.45
	115	160	286.4	2.16	2.49
26	60	126	233.2	2.83	3.27
	70	136	260.4	2.71	3.13
	90	151	284.5	2.40	2.77
	100	160	307.0	2.31	2.67
	115	165	326.8	2.32	2.68

#### Notes:

All precipitation rates are calculated for 180° operation. For the precipitation rate of a 360° sprinkler, divide by 2. All radius measurements are taken at standard rotation speeds. Slowing rotation to minimum rotation speed will add 10+ feet to the radius.



# ST-90 and STG-900 Rotors



## Unsurpassed reliability for small to midsize field applications

For smaller field layouts, the ST-90 and STG-900 Rotors provide cost-competitive solutions for radius ranges up to 120'. The ST-90 is designed for installation adjacent to the synthetic field, while the STG-900 is designed with the ability to install in a vault system located within the synthetic field.

ST-90  
ROTOR



STG-900  
ROTOR



**ST Vault:** Construction-grade, tapered fiberglass body shell with a polymer-concrete upper rim and cover, precast with openings to support the ST Rotor and Quick Coupler.



**ST Rotor:** For vault applications, the STG-900 Rotor is designed to fit perfectly in the vault for easy integration.

Rubber covers enhance safety with a smooth, flat rubberized surface area.



### KEY BENEFITS

- Water-lubricated gear drive for reliable operation without clogging
- Flexible arc adjustment from 40° to 360°
- QuickCheck™ Arc Mechanism for easy verification of arc setting
- Optional rubber cover for added safety on the field

### OPERATING SPECIFICATIONS

- Radius: 103' to 120'
- Flow: 74.5 to 92.0 GPM
- Operating pressure range: 100 to 120 PSI
- Nozzle trajectory: 22.5°
- Warranty: 5-year component part warranty

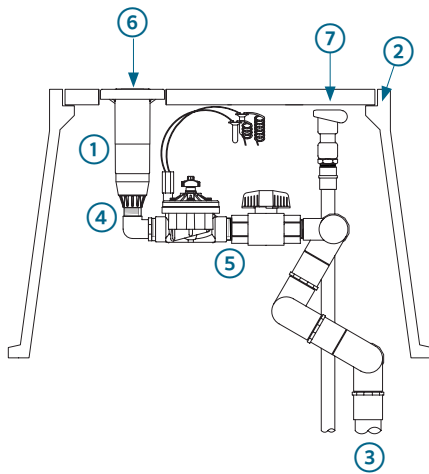

### ST-90 / STG-900 NOZZLE PERFORMANCE DATA

Nozzle	Pressure	Radius ft	Flow GPM	Precipitation in/hr	
	PSI			■	▲
73	100	103	74.5	1.35	1.56
	110	109	77.0	1.25	1.44
	120	115	79.6	1.16	1.34
83	100	112	84.2	1.29	1.49
	110	116	88.1	1.26	1.46
	120	120	92.0	1.23	1.42

#### Notes:

Requires minimum 100 PSI dynamic pressure supplied to swing joint inlet. All precipitation rates are calculated for 180° operation. For the precipitation rate of a 360° sprinkler, divide by 2.

### ST-90 MODELS

Model	Description
ST-90-73	3" pop-up, jar-top cap, adjustable arc, 1½" NPT inlet, 73 nozzle
ST-90-83	3" pop-up, jar-top cap, adjustable arc, 1½" NPT inlet, 83 nozzle

### STG-900 MODELS

Model	Description
STG-900-73	3" pop-up, top service, adjustable arc, 1½" Acme inlet, 73 nozzle
STG-900-83	3" pop-up, top service, adjustable arc, 1½" Acme inlet, 83 nozzle

### STG-900-KIT SYSTEM COMPONENTS

①	STG-900-83	Synthetic turf rotor
②	ST-173026-B	Vault
③	ST-2008-VA	Multi-axis vertical alignment swing joint
④	239800	1½" female Acme x male Acme fitting
⑤	ST-VBVF-K	Valve kit
⑥	473900SP	Rubber cover
⑦	HQ-5RC	Quick Coupler 1" inlet with 1¼" outlet for key



Helping our customers succeed is what drives us. While our passion for innovation and engineering is built into everything we do, it is our commitment to exceptional support that we hope will keep you in the Hunter family of customers for years to come.

A white, handwritten signature of Gregory R. Hunter.

Gregory R. Hunter, CEO of Hunter Industries

A white, handwritten signature of Gene Smith.

Gene Smith, President, Landscape Irrigation and Outdoor Lighting

**Website** [hunterindustries.com](http://hunterindustries.com) | **Customer Support** 1-800-383-4747 | **Technical Service** 1-800-733-2823